

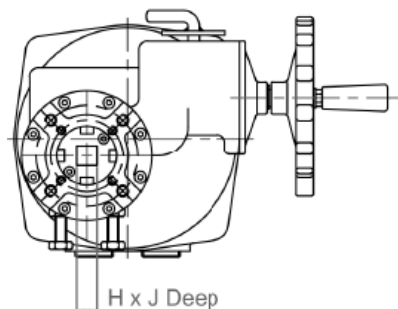

AfriGreen<sup>®</sup>  
African Green Distribution (Pty)

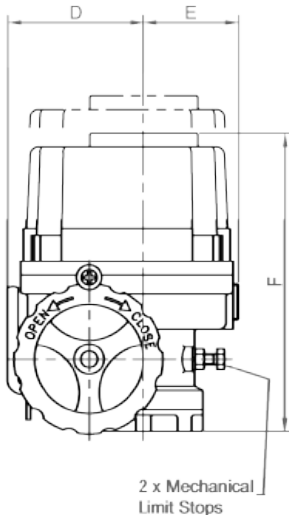

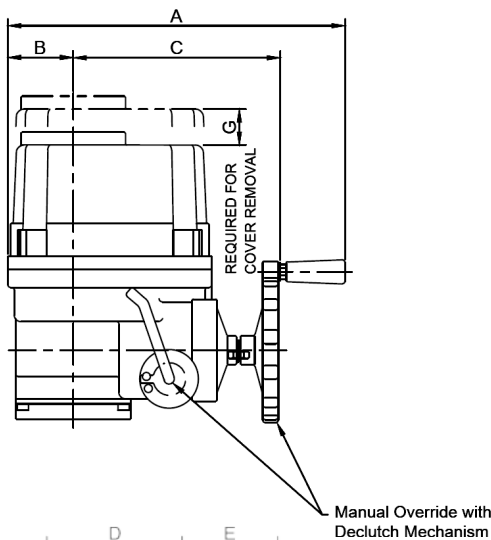

## HQ Electric Actuator for Albion Ball & Butterfly Valves

### Features

- Wide range of output torques
- Alloy Gearing
- Control Options include 4-20ma positioner and failsafe
- Die cast aluminium housing
- Multi Voltage Options

### Standard Specification

Enclosure	: Weatherproof IP67 (IP68 Option)
Power Supply	: 110/220v 50/60Hz, 24vAC/DC, 380/440V 3Phase
Duty Cycle (On/Off Duty)	: S4, 70% Standard, 100% for max 30 mins
Motor	: Squirrel Caged Induction Motor
Limit Switches	: 4 x SPDT, 250V AC 10A
Torque Switches	: 2 x SPDT, 250vAC 10A (HQ015-HQ120)
Space Heater	: 10W(110/220VAC) Anti Condensation
Conduit Entries	: 2 x M25 (PG 13.5 OR 1/2" NPT Option)
Travel Angle	: 90° ± 5°
Ambient Temperature	: -20°C to +70°C On/Off, -20° to +55° Modulating
External Coating	: Anodised before Dry Powder Polyester Coating

### Performance

MODEL	HQ8	HQ15	HQ20	HQ30	HQ50	HQ60	HQ80	HQ120
TORQUE (Nm)	80	150	200	300	500	600	800	1200
SPEED 90 50/60hZ	16/13	25/21	25/21	31/26	31/26	31/26	34/28	34/28
CURRENT 110/1/50	1.1	1.65	1.67	1.86	3.62	3.62	4.1	4.2
(A) 220/1/50	0.55	0.88	0.89	0.92	1.58	1.62	2.2	2.35
24VAC/DC	3.7	5.3	6.5	8.6				
WEIGHT (Kg)	7.4	16.6	16.6	22	23	23	29	29
STANDARD SQ SIZE	14	17	17	22	22	27	27	36

### Dimensions

MODEL	BASE	A	B	C	D	E	F	G	H*	J
HQ8	F07	258	50	157	100	70	235	120	14	35
HQ15	F07/F10	338	73	200	142	87	268	160	17	45
HQ20	F07/F10	338	73	200	142	87	268	160	17	45
HQ30	F10/F12	368	82	221	160	99	290	180	22	52
HQ50	F10/F12	368	82	221	160	99	290	180	22	52
HQ60	F10/F12	368	82	221	160	99	290	180	27	52
HQ80	F12/F14	410	103	242	186	111	330	210	27	60
HQ120	F12/F14	410	103	242	186	111	330	210	36	60

\* Can be machined to suit most valve stems (on request)

# AVION

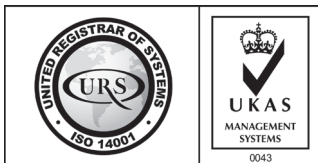

URS is a member of Registrar of Standards (Holdings) Ltd.

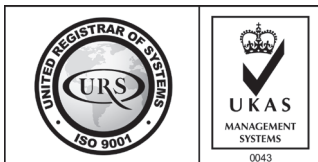

URS is a member of Registrar of Standards (Holdings) Ltd.

Distributor