



AfriGreen<sup>®</sup>  
African Green Distribution (Pty)



## HQ Electric Actuator for Albion Ball & Butterfly Valves



### Features

- Multi Voltage Options
- High corrosion resistance, anodized & painted housing
- Torque output: 50 Nm
- Low current, long-life actuator due to unique brushless DC motor
- Visual beacon indicator & LED lamps
- 70% Duty Rating (on/off only)
- Dec clutchable manual override handwheel
- Electronic torque limiter

### Standard Specification

Enclosure	: Weatherproof enclosure IP67
Power supply	: 85 - 265 VAC 1ph, 50/60 Hz   24 VAC/DC
Duty cycle	: S4: 70% (average load of 80% Max. torque) S2: 50% (average load of 80% Max. torque)
Motor	: BLDC motor
Limit switches	: 2 x open/close, SPDT, 250 V ac 10 A rating
Additional limit switches	: 2 x open/close, SPDT, 250 V ac 10 A rating
Anti-condensation board	: 2 W
Manual override	: Manual Handwheel
Cable entries	: 2 x M20
Movement angle	: 320 ± 10° (0 - 330°)
Ambient temperature	: -20°C to +80°C

### Optional Specification

PIU	: Potentiometer unit (1-10 kΩ)
PCU	: Proportional control unit (in/out: 0-10V or 4-20 mA)
*CPT	: Current position transmitter (output: 4-20mA dc)
WTA	: Watertight enclosure actuator (IP68 10 m 72 hr)
TS	: Torque overload indicator via flashing LED module

\*NOTE: These options are currently under development

### Performance

MODEL	MAXIMUM OUTPUT TORQUE	OPERATING TIME 50/60Hz - 90°	MOUNTING BASE ISO 5211
HQ5	50NM	13 SEC	F03/F04/F05/F07 - 14mm STAR

MODEL	RATED CURRENT (A)				WEIGHT
	110VAC	220VAC	24VAC	24VDC	
HQ5	0.1	0.05	0.8	0.8	2.6kg

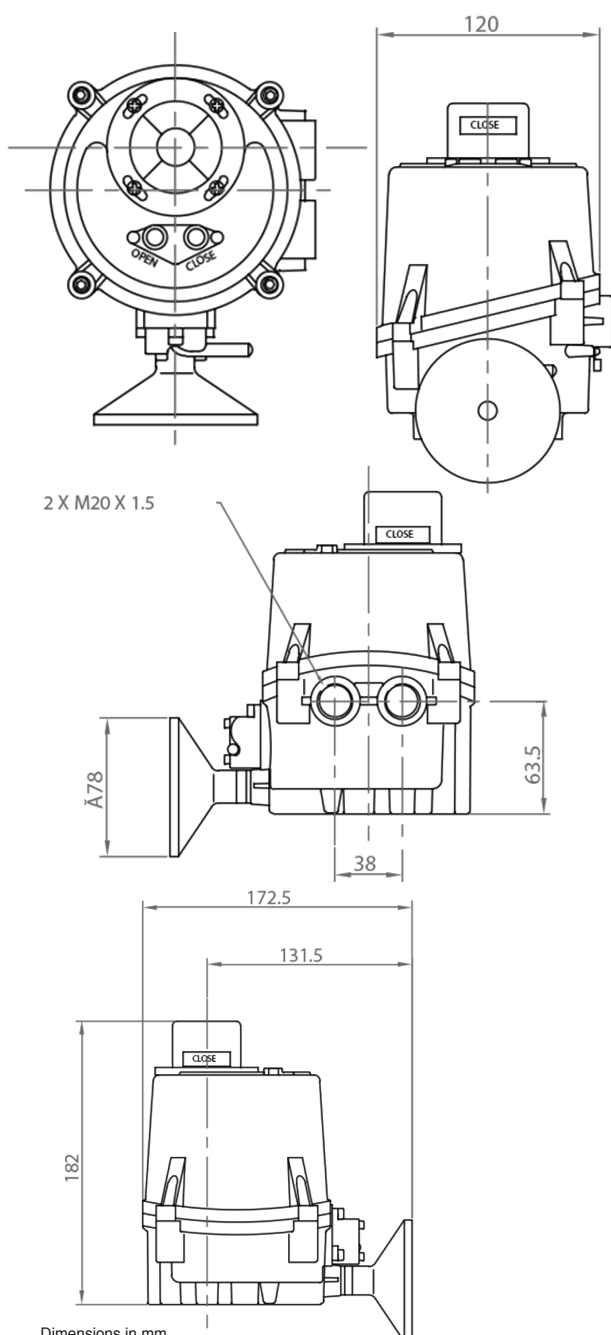

Dimensions in mm

This data sheet is designed as a guide and should not be regarded as wholly accurate in every detail. We reserve the right to amend the specification of any product without notice.

# AVION

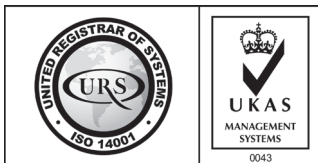

URS is a member of Registrar of Standards (Holdings) Ltd.

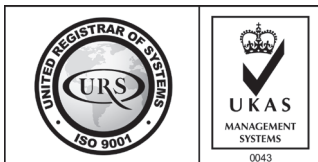

URS is a member of Registrar of Standards (Holdings) Ltd.

Distributor